

Exponent[®]

Failure Analysis Associates

**Evaluation of the
Gilbert Demonstration**



Evaluation of the Gilbert Demonstration

Prepared for

Bowman & Brooke, LLP
1741 Technology Drive, Suite 200
San Jose, CA 95110

Attorneys for
Toyota Motor Corporation and
Toyota Motor Sales, USA, Inc.

Prepared by

Exponent Failure Analysis Associates
149 Commonwealth Dr.
Menlo Park, CA 94025

March 2010

© Exponent, Inc.

Doc no. 0907698.000 A0T0 0310 GILB

Contents

	<u>Page</u>
List of Figures	iv
Acronyms and Abbreviations	v
Executive Summary	vi
1 Introduction	1
2 Findings from Reviewing ABC News Video and Article	2
2.1 Description of Dr. Gilbert’s Testing	2
2.2 Concerns with the ABC News Video Demonstration Presentation	3
3 2010 Avalon and 2007 Camry Testing	5
3.1 2010 Toyota Avalon	5
3.2 Testing a 2007 Toyota Camry	6
4 Dr. Gilbert’s Demonstration and the Real World	8
4.1 Loss of Insulation from the VPA1 Wiring	10
4.2 Loss of Insulation from the VPA2 Wiring	11
4.3 Loss of Insulation from the Power (VCP) Wiring	11
4.4 Establishing an Electrical Connection between VPA1 and VPA2	11
4.5 Obtaining a Specific Resistive Short between VPA1 and VPA2	12
4.6 Establishing an Electrical Connection between VPA2 and VCP	13
4.7 Sequencing of Electrical Short Circuits	14
4.8 Fault Tree Analyses of Dr. Gilbert’s Protocol	14
4.9 Accelerator Pedal/ECM Connector and Wiring Harness	16
4.10 Compromise of the Insulating Capacity of Conductors and Electrical Connection Mechanisms	17
4.10.1 Wiring Insulation Failures	17
4.10.2 Connector Failures	18
4.10.3 Electronic Module (ECM and Pedal) Failures	19

5	Testing Non-Toyota Vehicles	20
5.1	2009 Mercedes E350	20
5.2	2003 BMW 325i	22
5.3	2008 Honda Accord	23
5.4	2006 Subaru Impreza Outback	25
5.5	2005 Chrysler Crossfire	26
5.6	Accelerator Pedal Sensor Output Voltages	28

Appendix A Wiring Harness to the Accelerator Pedal

List of Figures

	<u>Page</u>
Figure 1. A 200-ohm resistance is apparently connected between the output signals of the two pedal position sensors. A third wire is about to be inserted into one side of the resistance.	2
Figure 2. Idle speed condition of the vehicle prior to connecting the power supply to the resistor, ABC video at 2:15.	4
Figure 3. High engine speed resulting from signal manipulations, ABC Video at 2:15.	4
Figure 4. Tested 2010 Toyota Avalon.	6
Figure 5. Fault tree analysis for Gilbert demonstration (Avalon).	9
Figure 6. Flowchart of events for Gilbert demonstration (Avalon).	10
Figure 7. Effect of different resistances placed between pedal sensor wire outputs (VPA1 and VPA2).	13
Figure 8. Tested 2009 Mercedes E350.	21
Figure 9. Tested 2003 BMW 325i.	23
Figure 10. Tested 2008 Honda Accord.	24
Figure 11. Tested 2006 Subaru Impreza Outback.	26
Figure 12. Tested 2005 Chrysler Crossfire.	27
Figure 13. Accelerator pedal sensor output voltages.	29
Figure 14. Accelerator pedal sensor output voltages.	30
Figure A1. Male portion of connector.	1
Figure A2. Plastic connector shell surrounds inner connector pedestal to house female sockets. Rubber gasket helps make the connector waterproof. Recessed pins and insulating divider between pins electrically isolates adjacent sockets.	2
Figure A3. Each connector lead is insulated and protected by a polymeric grommet that helps make the connector waterproof and provides another layer of electrical isolation between sockets.	3

Acronyms and Abbreviations

ABC	American Broadcasting Company
CEL	Check engine light
DTC	Diagnostic trouble code
ECM	Engine control module
ECU	Electronic control unit
ETCS-i	Electronic throttle control system with intelligence
JASO	Japanese Automobile Standard Organization
OBD-II	On-board diagnostics, second generation
PCB	Printed circuit board
PVC	Polyvinyl chloride
rpm	Revolutions per minute
SUA	Sudden unintended acceleration
TMC	Toyota Motor Corporation
VCP1	5 volt supply wire to pedal position sensor 1
VCP2	5 volt supply wire to pedal position sensor 2
VIN	Vehicle identification number
VPA1	Primary accelerator pedal position signal wire
VPA2	Secondary accelerator pedal position signal wire

Executive Summary

Exponent Failure Analysis Associates (Exponent) was asked to evaluate a demonstration performed by Dr. David Gilbert, an Associate Professor at Southern Illinois University Carbondale, on a Toyota Avalon equipped with the Electronic Throttle Control System with Intelligence (ETCS-i). He demonstrated a sudden increase in engine speed and power output via intentional circuit manipulation, which was videotaped and subsequently shown by ABC News, described in an accompanying article, and posted on their website.¹ The ABC News article claims that Dr. Gilbert discovered an “Electronic Design Flaw Linked to Runaway Toyotas.” Dr. Gilbert also prepared a preliminary report that contained some discussions on his demonstration and his opinions about its implications.²

Exponent evaluated the demonstration by:

1. Reviewing the ABC News video and article
2. Reviewing Dr. Gilbert’s preliminary report (“Gilbert Preliminary Report”)
3. Testing a 2010 Toyota Avalon
4. Testing a 2007 Toyota Camry
5. Studying the required sequence of events in the context of the real world
6. Testing non-Toyota vehicles

As a result of Exponent’s evaluation, we came to the following conclusions.

Dr. Gilbert’s demonstration, as shown on the ABC News website, amounts to little more than connecting three of the six pedal sensor wires to an engineered circuit to achieve engine revving. Dr. Gilbert clearly acknowledges this at the beginning of the video as he carefully

¹ <http://abcnews.go.com/Blotter/toyota-recall-electronic-design-flaw-linked-toyota-runaway-acceleration-problems/story?id=9909319>

² Toyota Electronic Throttle Control Investigation, Preliminary Report, David W. Gilbert, PhD and Omar Trinidad, 2/21/2010

describes this as an “event” he created in his lab, not one which he observed on an accident vehicle. For such an event to happen in the real world requires a sequence of faults that is extraordinarily unlikely. Furthermore, the individual “faults” required individually are far more likely to result in a detectable problem (for example, setting a trouble code or entering a fail-safe mode of operation), than combining in just the right manner to produce a sudden unintended acceleration (SUA) event.

Dr. Gilbert made no probability assessment of his demonstrated scenario, or of the likelihood of it actually occurring to vehicles in the field. In addition, resistive or short circuit faults having the characteristics of the rewired circuit that Dr. Gilbert created in his demonstration would undoubtedly leave a “fingerprint” on the physical wiring or other components of the vehicle, which could include witness marks and other telltale signs of their existence (e.g., breached insulation, contamination between wires, low impedance measurements between wires, stains, etc.). Dr. Gilbert has presented no evidence of his postulated sequence actually occurring in a real vehicle, or even evidence of an incipient event (e.g., signs that a resistive fault was developing), and did not look at any incident vehicles for “fingerprints” of any such fault.

Not all Toyota vehicles will respond with a sudden increase in engine speed and power output when subjected to the rewiring shown in Dr. Gilbert’s demonstration. For example, the 2007 Camry will set a diagnostic trouble code (DTC) and switch to a fail-safe mode of operation if Dr. Gilbert’s specific sequence is followed. To bypass setting the DTC on the 2007 Camry, Exponent slightly modified the parameters of Dr. Gilbert’s demonstration. By carefully engineering the modification, Exponent was able to rewire the pedal sensors and achieve engine revving without setting a DTC.

Exponent also evaluated how vehicles made by other manufacturers would respond to the same rewiring that Dr. Gilbert showed in his demonstration. Every vehicle from other manufacturers tested by Exponent could be induced to respond with a sudden increase in engine speed and power output, although the parameters of the rewiring changed slightly from vehicle to vehicle. These demonstrations in no way indicate a defect with any of the vehicles tested (including the Toyota Avalon and Camry).

Rather than providing a plausible root cause for apparent SUA events as reported by consumers, Dr. Gilbert's scenario amounts to connecting the accelerator pedal sensors to an engineered circuit that would be highly unlikely to occur naturally, and that can only be contrived in the laboratory. Using slight variations on Dr. Gilbert's scenario, other makes of vehicles responded in a manner similar to the 2010 Avalon and 2007 Camry when rewired. These findings illustrate the artificial nature of Dr. Gilbert's demonstration and its inability to explain reported incidents of SUA.

1 Introduction

Dr. David Gilbert, an Associate Professor at Southern Illinois University Carbondale, performed a demonstration on a Toyota Avalon equipped with the ETCS-i. He demonstrated an induced sudden increase in engine speed and power output that was video documented and later shown on ABC News and put on its website with an accompanying article. The Gilbert Preliminary Report also contained some discussions about his demonstration and his opinions concerning its implications. Exponent was asked to evaluate Dr. Gilbert's demonstration, the rewiring sequence required, and any relationship his laboratory-created sequence of faults might have to SUA events reported by consumers.

Section 2 discusses our observations and findings from reviews of ABC's video and article, and the Gilbert Preliminary Report.

Section 3 discusses our testing of a 2010 Avalon and 2007 Camry employing the sequence of rewiring events that Dr. Gilbert discussed in his demonstration.

Section 4 analyzes and compares Dr. Gilbert's sequence of rewiring events in the context of the real world. Sections 4.8 - 4.10 include a fault tree analysis of Dr. Gilbert's demonstration, an analysis of the connector at the pedal sensor and the wiring between the connector and engine control module (ECM), and a discussion of mechanisms that can lead to a compromise in the insulating capacity of the wiring, connectors and electronic boards.

Section 5 discusses our testing of non-Toyota vehicles, and the implications of these results to some of the conclusions stated in the Gilbert Preliminary Report.

2 Findings from Reviewing ABC News Video and Article

2.1 Description of Dr. Gilbert's Testing

Dr. Gilbert was shown on the ABC News website on February 22, 2010. He claimed to have discovered a “design flaw” that produced sudden acceleration in certain Toyota vehicles. Dr. Gilbert demonstrated the laboratory-induced faults for ABC’s Brian Ross using a Toyota Avalon. As shown in Figure 1, a 200-ohm resistance was apparently connected by Dr. Gilbert between the output signals of the two pedal position sensors.



Figure 1. A 200-ohm resistance is apparently connected between the output signals of the two pedal position sensors. A third wire is about to be inserted into one side of the resistance.

The two independent accelerator pedal position sensors produce different output voltages that are fed to the ECM of the vehicle, and are used by the ECM to compute a throttle setting and to assess whether the pedal signals are valid. Figure 1 also shows Dr. Gilbert holding a wire that he then connected to one side of the 200-ohm resistor.³ The other side of the wire was apparently connected to the 5-volt power supply for one of the pedal’s sensors.³ These manipulations changed the signals that were coming from the pedal, feeding higher voltages to

³ The Gilbert Preliminary Report states this connection can only be made to the secondary pedal sensor output signal VPA2 to cause the throttle to open (p 11)

the ECM. These higher voltages were interpreted by the ECM as indicating an increase in accelerator application, causing the engine speed to increase.

Dr. Gilbert intentionally created two sequential faults. The first fault required that the insulation be mechanically defeated on the wires carrying the two pedal position sensor outputs, and then required connecting these two wires with a carefully chosen resistor. The second fault required that more insulation be mechanically defeated on a power supply wire and then formed a low resistance connection between this wire and the output of pedal position sensor #2. These faults must be mechanically created in the prescribed sequence and with strict limits on the value of the resistance between the insulation defeats to avoid detection by the ECM. This will be discussed more fully in a later section.

2.2 Concerns with the ABC News Video Demonstration Presentation

The ABC News video shows the tachometer (engine speed) rising from under 1,000 to over 6,000 rpm in less than a second, and then the vehicle is shown accelerating. Near the end of the video, Dr. Gilbert uses a handheld Generation II on-board diagnostics scanner (OBD-II) to show that the vehicle has not stored any DTCs.⁴

The sequence of these events in the video has been manipulated. Specifically, at approximately 2:15 minutes into the video, Dr. Gilbert is shown plugging a connector into a resistance box while the vehicle is being driven (Figure 1). The next video sequence shows the vehicle's tachometer jumping from less than 1,000 to over 6,000 rpm in less than a second. The implied correlation is highly misleading. The video frames have been spliced to create the illusion that the sudden increase in engine speed shown on the tachometer was actually occurring while the vehicle is driving. Exponent captured still frames of the tachometer from the video images which are shown in Figure 2 and Figure 3. These frames clearly show the vehicle speedometer needle is at zero (0) and warning lights are on indicating that: 1) the vehicle doors are open, 2) the parking brake is engaged, and 3) the driver is unbelted. Also, the vehicle transmission indicator is showing "Park." The available evidence demonstrates that the tachometer sequence

⁴ Dr. Gilbert identified his OBD-II tool as an Actron AutoScanner Plus scanner (Gilbert Preliminary Report, p 8)

was not filmed while the vehicle was moving (as implied in the ABC News video), but rather while the vehicle was parked. If the vehicle had been driven, the engine could not have responded as rapidly to the external faults created by Dr. Gilbert as shown in the video. This deliberate manipulation of chronology was not disclosed to ABC viewers.



Figure 2. Idle speed condition of the vehicle prior to connecting the power supply to the resistor, ABC video at 2:15.



Figure 3. High engine speed resulting from signal manipulations, ABC Video at 2:15.

3 2010 Avalon and 2007 Camry Testing

3.1 2010 Toyota Avalon

Exponent recreated Dr. Gilbert's demonstration using the 2010 Avalon shown in Figure 4.⁵ This involved precise mechanical creation of two sequential wiring faults. Exponent inserted a set of jumper wires between the pedal assembly and the wiring harness connector to the pedal. The jumper wires enabled electrical interconnections between the wires that carry power and pedal position signals between the accelerator pedal and the ECM. The two wires that carry the pedal position signals from the accelerator pedal to the ECM were electrically connected through a 200-ohm resistance. Adding the resistance did not noticeably change the operation of the engine, though increasing or decreasing this resistance more than a limited amount would set a DTC (immediately if the resistance was too low, or later when the second fault was created.) To cause an increase in engine speed, Exponent then connected one of the 5-volt power supply wires from the accelerator pedal to the secondary accelerator pedal position signal wire (VPA2) using another jumper wire. Exponent's recreation of the Gilbert demonstration on the Avalon resulted in an apparent "sudden" onset of acceleration and engine revving, similar to that shown in Dr. Gilbert's demonstration. The apparent "sudden" onset of the acceleration was due to artificially creating the second fault in an instantaneous manner after the carefully engineered first fault.

During the demonstration, the check engine light (CEL) did not illuminate. After the demonstration, the vehicle's computer was checked using an OBD II tool and no DTCs were set. Exponent obtained the same results as those shown by Dr. Gilbert in the ABC News broadcast.

Note that the Gilbert demonstration was produced under highly artificial conditions where multiple faults and specific resistances and power supplies were mechanically wired into the system through external means. If such circuit faults were to actually occur without deliberate

⁵ VIN: 4T1BK3DBZAU359937; build date: Oct. 2009

circuit manipulation in an operating vehicle, the physical presence of such faults would unquestionably leave “fingerprints,” as discussed later.



Figure 4. Tested 2010 Toyota Avalon.

3.2 Testing a 2007 Toyota Camry

Dr. Gilbert’s demonstration was re-created on a 2007 Toyota Camry.⁶ Again, Exponent mechanically inserted a set of jumper wires between the pedal assembly and the wiring harness connector to the pedal. Using the jumper wires, the two pedal output sensors were electrically connected through a 200-ohm resistance. At this point, the procedure used in Dr. Gilbert’s fault creation protocol had to be modified slightly because DTCs would set and the car would enter a fail-safe mode every time the VPA2 was connected to the 5-volt power supply line. Exponent found that carefully adding an engineered resistance of 100 ohms between the 5-volt line and VPA2 would cause the engine to rev high (with the transmission not in gear), though resistances

⁶ VIN: JTNBE46KX73061175, Oct. 2006

as low as 15 ohms and as high as 200 ohms would affect engine speed to various degrees without setting a DTC.

4 Dr. Gilbert's Demonstration and the Real World

Exponent evaluated Dr. Gilbert's demonstration to determine if his fault creation protocol represented a realistic failure scenario for Toyota vehicles.

Exponent's evaluation of Dr. Gilbert's methodology included:

- Identifying fault events that would be necessary to result in engine revving using the circuit manipulation upon which Dr. Gilbert's demonstration is based.
- Comparing Dr. Gilbert's fault inducement with potential realistic failure scenarios.

Our analysis illustrates that Dr. Gilbert's scenario requires a complex combination of multiple faults or failures, and that these faults must occur in a precise sequence to produce the "Top" failure event, namely an unintended engine revving with no DTC. These fault events and conditional probabilities are identified as follows:

- Loss of insulation from the primary accelerator pedal position signal wire (VPA1) wiring, or a compromise of its insulating capacity.
- Loss of insulation from the VPA2 wiring, or a compromise of its insulating capacity.
- Loss of insulation from the power supply wiring to the accelerator pedal (VCP1 or VCP2, referred to as VCP), or a compromise of its insulating capacity.
- Establishing an electrical connection between VPA1 and VPA2.
- Obtaining a specific resistive short between VPA1 and VPA2.
- Establishing an electrical connection between VPA2 and VCP1.

- Electrical short circuits occurring in this specific sequence.

The relationships between the identified fault events are captured in the fault tree diagram shown in Figure 5, and in the flowchart of events shown in Figure 6.

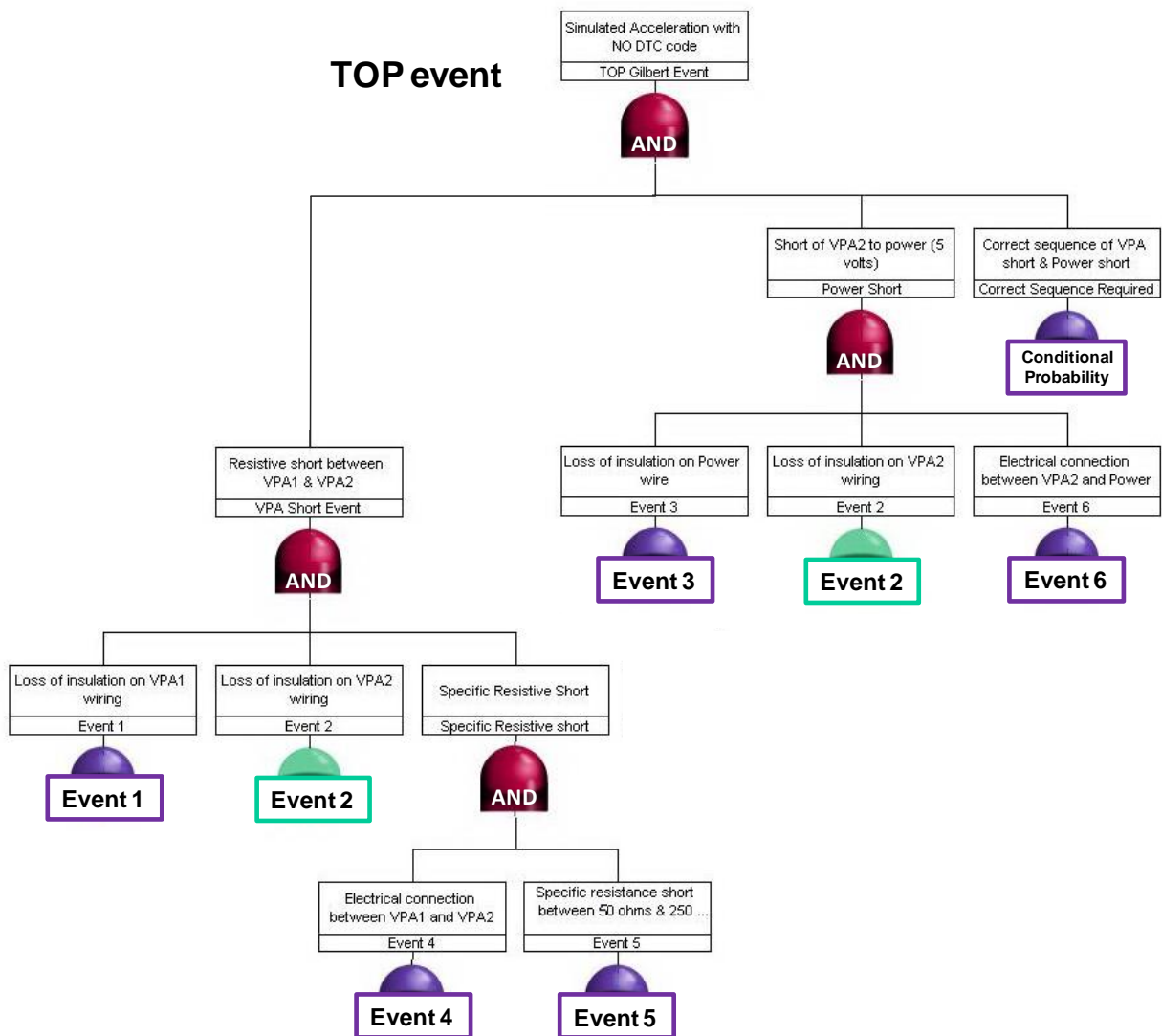

Figure 5. Fault tree analysis for Gilbert demonstration (Avalon).

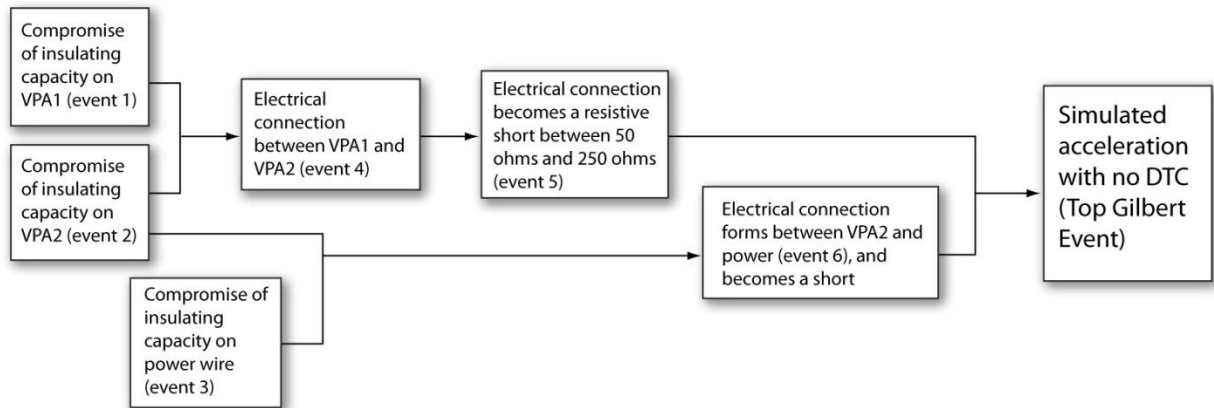

Figure 6. Flowchart of events for Gilbert demonstration (Avalon).

4.1 Loss of Insulation from the VPA1 Wiring

A compromise of the insulating capacity of the VPA1 conductor – whether cable wire, connector pins, or printed circuit board (PCB) traces – is required to enable the formation of an electrically conductive connection between VPA1 and VPA2. Dr. Gilbert mechanically breached the insulation of VPA1 to provide access to the accelerator pedal sensor conductors. In actuality, such an artificial electrical connection is unrealistic since normal access to the accelerator pedal connections is not provided to vehicle operators. To achieve such a compromise of the insulating capacity of the conductor in reality, several mechanisms were considered and are discussed in more detail in Section 4.10. As discussed in that section, if the insulating capacity of the conductor were compromised, it would be visible. No such insulation faults have been observed on any of the ECMs, connectors or wiring harnesses inspected to date.

Our analysis of the connector and the wiring harness, detailed in Section 4.9, discusses the mechanical and electrical design resistance to moisture ingress and to dielectric breakdown of the wiring and connectors.

4.2 Loss of Insulation from the VPA2 Wiring

A compromise of the insulating capacity of the VPA2 conductor – whether cable wire, connector pins or printed circuit board (PCB) traces – is required to enable the formation of an electrically conductive connection between VPA1 and VPA2, and between VPA2 and VCP. The observations in the Section 4.1 apply to this section.

4.3 Loss of Insulation from the Power (VCP) Wiring

There are two power lines supplying 5 volts to the accelerator pedal, which are called VCP1 and VCP2. Either line can be used for Dr. Gilbert's demonstration. In this report, VCP will be used to denote either VCP1 or VCP2 without preference. A compromise of the insulating capacity of the VCP conductor – whether cable wire, connector pins, or PCB traces – is required to enable the formation of an electrically conductive connection between VCP and VPA2. The observations in Sections 4.1 and 4.2 apply to this section.

4.4 Establishing an Electrical Connection between VPA1 and VPA2

According to the Gilbert protocol, an electrical connection between VPA1 and VPA2 is required. This is a fault event that requires the compromise of the insulating capacity of both VPA1 and VPA2 conductors, as discussed earlier. Dr. Gilbert achieved this electrical connection between VPA1 and VPA2 artificially by wiring a precisely selected resistor into breaches of the electrical wiring that he intentionally created. In reality, such an unintended electrical connection is unlikely to occur for several reasons, not the least of which is that the accelerator pedal connections and wiring are not readily accessible to vehicle operators, so they are unlikely to create it by accident. Another consideration is that should two mechanical compromises of the insulation occur, they must form in sufficiently close proximity to one another, or the formation of a fault between them having the appropriate resistive characteristics will not occur.

To achieve such an electrical connection under real world field conditions, several mechanisms have been considered and are discussed in more detail in Section 4.10. As discussed in Section

4.10, if the insulating capacities of the conductors were compromised so that a resistance of the appropriate characteristic was formed, it would be visible and ultimately detected. No such observations were made on any of the used ECMs, connectors or wiring harnesses inspected to date.

These factors make it highly unlikely that an electrical connection between VPA1 and VPA2 having the appropriate resistive characteristics would occur in the field.

4.5 Obtaining a Specific Resistive Short between VPA1 and VPA2

In addition to achieving an electrical connection between VPA1 and VPA2, Dr. Gilbert's protocol would not achieve the simulated acceleration without the VPA1-to-VPA2 electrical connection having a specific and narrow range of electrical resistance.

Exponent has performed testing and analysis to determine the range of electrical resistances for the 2010 Avalon that would result in the simulated acceleration. It was determined that the necessary resistance must be between approximately 50 and 250 ohms. Resistances outside this range may result in a DTC. Figure 7 summarizes this finding and illustrates the narrow range of resistances to which Dr. Gilbert's demonstration is confined. It is highly unlikely that a fault could be created under real world conditions that would land in this narrow band of electrical resistances (and stay there) without setting a DTC.

2010 Toyota Avalon

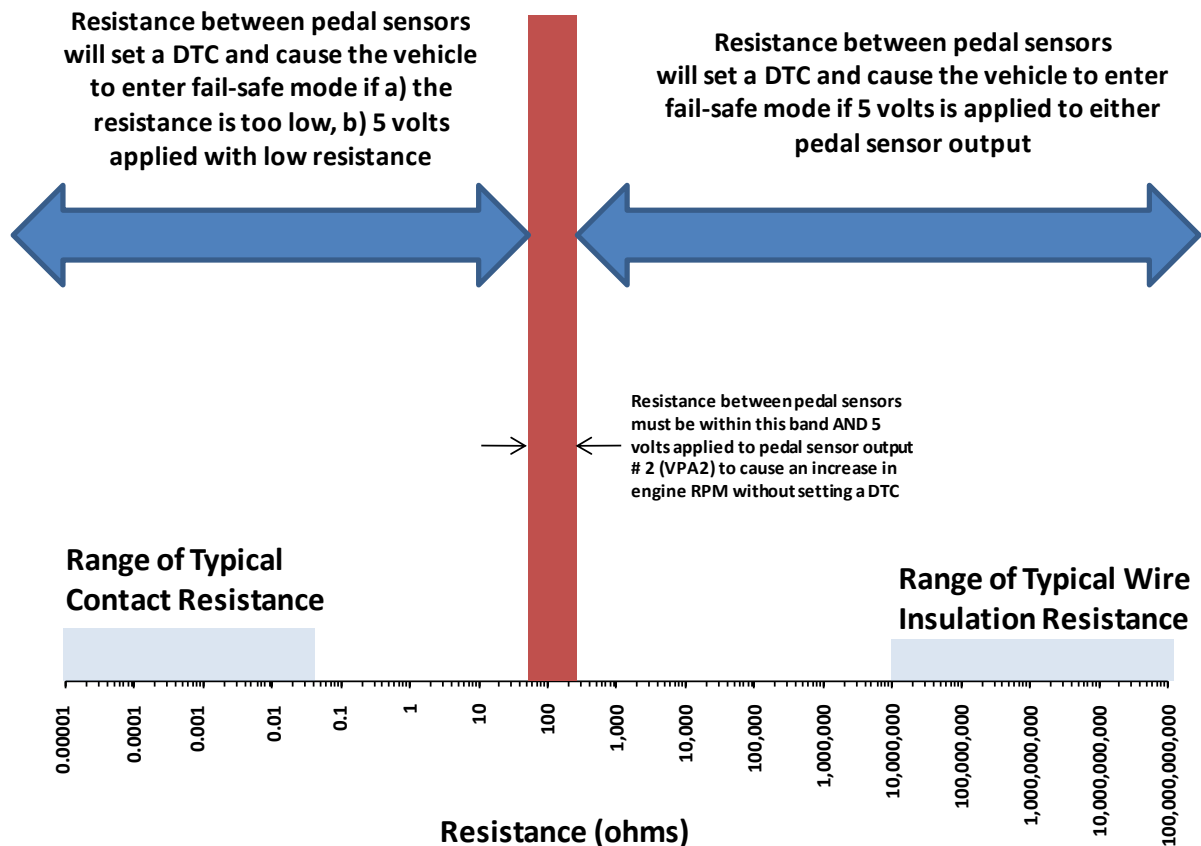

Figure 7. Effect of different resistances placed between pedal sensor wire outputs (VPA1 and VPA2).

4.6 Establishing an Electrical Connection between VPA2 and VCP

According to Dr. Gilbert’s protocol, an electrical connection between VPA2 and VCP must form after the VPA1-VPA2 resistance is reliably established.⁷ This is a fault event that requires a compromise of the insulating capacity of both the VPA2 and VCP conductors. However, this fault is a separate event, not a common failure to another event. Dr. Gilbert achieved this electrical connection between VPA2 and VCP artificially, by physically shorting the breached wires with external jumper wires.

⁷ Should this fault occur before the formation of a stable resistance between the VPA1-VPA2 connection, a DTC is generated.

To achieve such an electrical connection under real world conditions, several mechanisms have been considered and are discussed in more detail in Section 4.10. As concluded in Section 4.10, a compromise of the insulating capacity of the conductors that result in a direct electrical connection in reality would be readily detectable after a vehicle experienced an SUA event. No such observations were made on any of the analyzed ECMs, connectors or wiring harnesses inspected to date.

4.7 Sequencing of Electrical Short Circuits

Dr. Gilbert's protocol would not cause engine revving unless the electrical faults he intentionally introduced occur in a specific sequence. For example, if VPA2 and VCP1 (or VCP2) were electrically connected before the VPA1-to-VPA2 fault was reliably formed, or did not possess the appropriate resistance characteristics (Figure 7) a DTC would be set, and the engine would enter a fail-safe mode of operation.

Note that electrical connections between lines other than between VPA1-to-VPA2, and VPA2-to-VCP will not result in engine revving and may instead result in setting a DTC.

4.8 Fault Tree Analyses of Dr. Gilbert's Protocol

Dr. Gilbert's protocol requires six separate mechanical events with electrical consequences. In addition, these six separate events must occur in a specific sequence. Having such a sequence of independent events occur in the field is extraordinarily unlikely.

Common causes, such as cutting the insulation of multiple wires at the same time, might reduce the count of specific independent events. The act of cutting wires, however, can introduce other opportunities to trigger DTCs (for example, by shorting wires to ground or the wrong wires to each other). Furthermore, wire insulation damage will not self-heal and will be detectable.

Because of the low probability of occurrence, NASA teaches, in its “Fault Tree Construction Ground Rules,” the following:⁸

Do not model wiring faults between components. Generally, wiring faults, such as shorts to ground and shorts to power, have very low probabilities compared to probabilities of major components failing.

As the NASA citation indicates, the probability of occurrence of such wiring faults is so low that NASA instructs not to model it. Much less, the Gilbert demonstration contains two such wiring faults plus additional requirements.

In fault tree analyses, scenarios or “TOP” events requiring three or more independent fault events are not considered as dominant contributors because the likelihood of occurrence of three or more independent fault events is remote. In Dr. Gilbert’s demonstration, six fault events and an additional conditional probability (due to the constraint of a specific event sequence) are required (Figure 5). Even under conservative assumptions that take into consideration the possibility of common cause events, at least three independent fault events are required to cause engine revving in the field using the concept on which Dr. Gilbert’s protocol is based.

One of the challenges in diagnosing many of the alleged sudden acceleration events is that the faults do not reappear after the engine is turned off and on. Dr. Gilbert’s demonstration does not account for this behavior. Indeed, with all of the faults needed to make his demonstration occur, there would be ample observable evidence of these faults (such as insulation breaches, discoloration or staining on a connector or electronic board, conductive filament formation, etc.).

Dr. Gilbert artificially reconfigured the vehicle’s electronic system by rewiring the circuits and introducing a highly unlikely set of complex fault conditions. Essentially, Dr. Gilbert designed an external circuit that simulates the electrical signals produced when the pedal is depressed. By effectively redrawing the electronic circuitry, Dr. Gilbert unrealistically defeated built-in safeguards to achieve the end result of engine revving.

⁸ *Fault Tree Analysis with Aerospace Applications, Version 1.1*, NASA Office of Safety and Mission Assurance, NASA Headquarters, Washington, DC 20546, August, 2002, pg. 67

4.9 Accelerator Pedal/ECM Connector and Wiring Harness

The accelerator pedal connector is constructed in two halves, namely the male portion, which is attached to the accelerator pedal, and the female portion, which is attached to the connecting wire harness. Exponent's observations regarding the connector design are presented in this portion of the report. Photographs and a bullet-item description of the connectors are provided in Appendix A.

The connector, when in service and when mated to the female connector on the pedal, is located within the passenger compartment of the vehicle, up underneath the dashboard. Therefore, the opportunity for liquids to contact the connector is extremely limited. Furthermore, the connector is located sufficiently high above the driver's side floor mat to minimize any moisture ingress from the driver's footwear. Also, the connector is located sufficiently far away from the vehicle's heater core and its coolant supply hoses that should a leak occur, the chances of an internal connector parasitic connection due to moisture ingress would be very unlikely since the connector is built to waterproof standards and thus has safeguards against conductive fluid shorts.

The two halves of the connector cannot be separated without the disengagement of an interlocking clasp. When separated, the connector's two halves reveal features of the connector, which include a protective shell, polymer gaskets, insulated wires, and recessed pins. The female portion of the connector was designed with an integral rubber gasket that serves several purposes:

- It acts as a grommet that provides a waterproof seal between the connector housing and the insulation of the wires that penetrate the connector's shell.
- It acts as an electrical insulator between the individual connecting wires.

The connector's pins are recessed and separated by insulating plastic that serves to prevent adjacent pin electrical interconnection. The accelerator pedal assembly itself is made from molded plastic with its internal electronics also molded in the same pedal

housing. Such an assembly prevents moisture and liquid from coming into contact with the accelerator pedal electronics.

Similarly, when the connector is mated to the ECM, these same design features of the connector help prevent any liquid migration or moisture entry into the ECM. Furthermore, the ECMs are environmentally protected by both the case and coatings on the PCB.

The individual electrical wires are insulated with PVC (polyvinyl chloride) insulation that is rated to the Japanese Automobile Standard Organization (JASO) D 608-92. The wire specifications require a variety of tests, such as subjecting the wiring to a “withstand voltage” test where 1,000 volts are applied to the cable while fully immersed in water. Under normal operating conditions, these wires carry 5 volts. It is highly unlikely that a compromise of the wires’ insulating capacities due to dielectric breakdown will occur at such low voltages and in their operating environment.

The connector and wiring harness exhibit a number of features that resist moisture ingress, liquid penetration and migration, and dielectric breakdown. Dr. Gilbert does not acknowledge the significant barriers to compromise of the insulating capacity of the hardware that is imposed by the technology inherent in their design. The connector and wiring are specifically designed to perform electrically in a highly reliable and robust manner in the vehicle.

4.10 Compromise of the Insulating Capacity of Conductors and Electrical Connection Mechanisms

There are known physical and chemical mechanisms that can cause a compromise of the insulating capacity of a conductor, whether it is in a wiring bundle, inside a connector, or inside an electronic module. These mechanisms are discussed in the following sections.

4.10.1 Wiring Insulation Failures

The individual electrical wires are insulated with PVC insulation that is rated to the Japanese Automobile Standard JASO D 608-92. The wires are subjected to a variety of test conditions that are more extreme than the environments seen by the accelerator pedal-to-ECM wiring.

Insulation breakdown, if it were to occur, would be the result of mechanical or chemical causes, since the voltages and currents carried by the wires are too small to damage the insulation. PVC insulation is ubiquitous in the automotive industry because it is well-suited to this environment. The wiring from the accelerator pedal is bundled, wrapped in plastic sheeting and placed inside a plastic conduit (called convoluted split loom tubing). If a contaminant capable of compromising the wiring insulation (very unlikely to be found in the consumer environment) were to penetrate the conduit in sufficient quantity to cause damage, it would be very unlikely that the Gilbert-engineered external circuit and sequence would result. Furthermore, evidence of such an event would persist, never “heal,” and be detectable and observable. Were the wiring insulation mechanically compromised (despite the protection against such an event), it would likewise be very unlikely that the Gilbert-engineered circuit and sequence would result. No such evidence of chemical or mechanical insulation failure has been found or reported to date. Such a fault would furthermore not be eliminated by turning the vehicle off then on.

Wiring harness insulation breakdown that would result in the narrow resistance range and event sequence required by Dr. Gilbert’s demonstration, without leaving any trace of its existence after engine cycling, is extremely unlikely and unsupported by the available evidence.

4.10.2 Connector Failures

The ECM, pedal module, and wiring harness connectors are all of similar construction in that they employ pins or sockets that are physically separated and electrically isolated from adjacent pins and contacts by insulating polymeric materials. The electrical breakdown characteristics of the connector polymers far exceed the electrical stresses inherent in the redundant 5V pedal module circuits. Connector failures that allow electrical connections to other contacts under such circumstances therefore occur due to contaminant intrusion, which is most often contaminated water.

These connectors contain seals that are designed to prevent liquid intrusion into the connector contact region. Both the mating connector bodies and the individual conductors themselves are sealed against liquid intrusion and tested to waterproof standards. Furthermore, these connectors are rarely, if ever exposed to liquid immersion or splashing. However, should liquid

intrusion occur and cause electrical connection between contacts within a connector, evidence of such intrusion and the electrical connection will remain. Turning the car ignition off and then on will furthermore not cause such evidence, or the reported symptoms, to disappear. Liquid intrusion that would produce the narrow resistance range and event sequence required by Dr. Gilbert's demonstration, without leaving any trace of its existence after engine cycling, is extremely unlikely and unsupported by the available physical evidence.

4.10.3 Electronic Module (ECM and Pedal) Failures

It is possible for electronic modules to fail and develop parasitic resistive connections.⁹ In general, such failures can develop over time and occur due to contaminants that remain after a part was manufactured, or due to contaminant intrusion that occurs while in service. These modules are sealed and coated or potted to prevent contaminant intrusion. Furthermore, should contaminant intrusion occur, evidence of such intrusion and the resulting parasitic resistive electrical connection(s) would remain. It is furthermore very improbable that Dr. Gilbert's precise resistance values and required sequence of connections would form under such conditions. No such evidence of contaminant intrusion has been found to date that has resulted in a simulated version of Dr. Gilbert's circuit. Turning the car off then on would furthermore not eliminate such a fault.

A module failure that would result in the narrow resistance range and event sequence required by Dr. Gilbert's demonstration, without leaving any trace of its existence after engine cycling, is extremely unlikely and unsupported by the available physical evidence.

⁹ "Tutorial, Failure-Mechanisms for Conductive-Filament Formation", IEEE Transactions on Reliability, Vol 43, No. 3, 1994, September.

5 Testing Non-Toyota Vehicles

Exponent also evaluated how other manufacturers' vehicles responded when subjected to Dr. Gilbert's protocol. The vehicles tested were a 2009 Mercedes E350, a 2003 BMW 325i, a 2008 Honda Accord, a 2006 Subaru Impreza Outback, and a 2005 Chrysler Crossfire.

5.1 2009 Mercedes E350

Dr. Gilbert's fault creation protocol was applied to the 2009 Mercedes E350 shown in Figure 8.¹⁰ As with the Avalon and Camry, this involved mechanically creating two sequential electrical faults. Exponent inserted a set of jumper wires between the pedal assembly and the wiring harness connector to the pedal. The jumper wires enabled electrical interconnections between the wires that carry power and position signals between the accelerator pedal and the ECM. Using these jumper wires, the two pedal sensor output wires were connected through a 200-ohm resistor. The resistance value was identical to that used by Dr. Gilbert when he tested his Avalon. To cause an increase in engine speed, Exponent connected a 5-volt power supply wire to the accelerator pedal through a second resistor of 100 ohms.¹¹ The demonstration on the 2009 Mercedes E350 resulted in an apparent "sudden" onset of acceleration and engine revving, similar to that shown in Dr. Gilbert's demonstration. The apparent "sudden" onset of the acceleration was due to artificially creating the second fault in an instantaneous manner.

¹⁰ VIN: WDBUF56X19B361075; build date: June 2008

¹¹ The pedal sensor with higher output voltage was connected through a resistance to the power supply; in our Avalon testing, we also connected the sensor with the higher output voltage to the power supply.



Figure 8. Tested 2009 Mercedes E350.

During the demonstration, the check engine light did not illuminate. After the demonstration, the vehicle's computer was checked using an OBD-II tool and no diagnostic trouble codes were set. Exponent obtained the same results as those shown by Dr. Gilbert in the ABC News video but with a 2009 Mercedes E350 using his protocol. Note that this demonstration was produced under highly artificial conditions where multiple mechanically-created electrical faults, specific resistances, and power supplies were wired into the system through external means to simulate depression of the accelerator pedal. If such circuit faults were actually to occur without deliberate circuit manipulation in an operating vehicle, the presence of such faults would certainly leave "fingerprints" as to their presence.

5.2 2003 BMW 325i

Dr. Gilbert's fault creation protocol was applied to the 2003 BMW 325i shown in Figure 9.¹² As with the Avalon and Camry, this involved mechanically creating two sequential electrical faults. Exponent inserted a set of jumper wires between the pedal assembly and the wiring harness connector to the pedal. The jumper wires enabled electrical interconnections between the wires that carry power and position signals between the accelerator pedal and the ECM. Using these jumper wires, the two pedal sensor output wires were connected through a 200-ohm resistor. The resistance value was identical to that used by Dr. Gilbert when he tested his Avalon. To cause an increase in engine speed, Exponent connected a 5-volt power supply wire to the accelerator pedal through a second resistor of 100 ohms.¹³ The demonstration on the 2003 BMW 325i resulted in an apparent "sudden" onset of acceleration and engine revving, similar to that shown in Dr. Gilbert's demonstration. The apparent "sudden" onset of the acceleration was due to artificially creating the second fault in an instantaneous manner.

During the demonstration, the check engine light did not illuminate. After the demonstration, the vehicle's computer was checked using an OBD-II tool, and no diagnostic trouble codes were set. Exponent obtained the same results as those shown by Dr. Gilbert in the ABC News video but with a 2003 BMW 325i. Note that this demonstration was produced under highly artificial conditions where multiple mechanically-created electrical faults, specific resistances, and power supplies were wired into the system through external means to simulate depression of the accelerator pedal. If such circuit faults were actually to occur without deliberate circuit manipulation in an operating vehicle, the presence of such faults would certainly leave "fingerprints" as to their presence.

¹² VIN: WBAAZ33463PH31229; build date: Oct. 2002

¹³ The pedal sensor with higher output voltage was connected through the resistor to the power supply; in our Avalon testing, we also connected the sensor with the higher output voltage to the power supply.



Figure 9. Tested 2003 BMW 325i.

5.3 2008 Honda Accord

Dr. Gilbert's protocol was applied to the 2008 Honda Accord shown in Figure 10.¹⁴ As with the Avalon and Camry, this involved mechanically creating two sequential electrical faults. Exponent inserted a set of jumper wires between the pedal assembly and the wiring harness connector to the pedal. The jumper wires enabled electrical interconnections between the wires that carry power and position signals between the accelerator pedal and the ECM. Through testing, it was found that a 300-ohm resistor could be used between the two pedal sensor output wires without setting a DTC. Using the jumper wires, the two pedal sensor output wires were connected through a 300-ohm resistor. This resistance is comparable, though slightly higher than the value of the resistor used on the 2010 Avalon by Dr. Gilbert. To cause an increase in engine speed, Exponent connected a 5-volt power supply wire to the accelerator pedal through a

¹⁴ VIN: 1HGCP36818A015878; build date: Oct. 2007

second resistor of 50 ohms.¹⁵ The demonstration on the 2008 Honda Accord resulted in an apparent “sudden” onset of acceleration and engine revving, similar to that shown in Dr. Gilbert’s demonstration. The apparent “sudden” onset of the acceleration was due to artificially creating the second fault in an instantaneous manner.



Figure 10. Tested 2008 Honda Accord.

During the demonstration, the check engine light did not illuminate. After the demonstration, the vehicle’s computer was checked using an OBD-II tool and no diagnostic trouble codes were set. Exponent obtained the same results as those shown by Dr. Gilbert in the ABC News video but with a 2008 Honda Accord. Note that this demonstration was produced under highly artificial conditions where multiple mechanically-created electrical faults and specific resistances were wired into the system through external means to simulate depression of the accelerator pedal. If such circuit faults were to actually occur without deliberate circuit manipulation in an operating vehicle, the presence of such faults would certainly leave “fingerprints” as to their presence.

¹⁵ The pedal sensor with higher output voltage was connected through the resistor to the power supply; in our Avalon and Camry testing, we also connected the sensor with the higher output voltage to the power supply.

5.4 2006 Subaru Impreza Outback

Dr. Gilbert's fault creation protocol was applied to the 2006 Subaru Impreza Outback shown in Figure 11.¹⁶ As with the Avalon and Camry, this involved mechanically creating two sequential electrical faults. Exponent inserted a set of jumper wires between the pedal assembly and the wiring harness connector to the pedal. The jumper wires enabled electrical interconnections between the wires that carry power and position signals between the accelerator pedal and the ECM. Using these jumper wires, the two pedal sensor output wires were connected through a 100-ohm resistor. To cause an increase in engine speed, Exponent connected a 5-volt power supply wire to the accelerator pedal through a second resistor of 50 ohms.¹⁷ The demonstration on the 2006 Subaru Impreza Outback resulted in an apparent "sudden" onset of acceleration and engine revving, similar to that shown in Dr. Gilbert's demonstration. The apparent "sudden" onset of the acceleration was due to artificially creating the second fault in an instantaneous manner.

During the demonstration, the check engine light did not illuminate. After the demonstration, the vehicle's computer was checked using an OBD-II tool, and no diagnostic trouble codes were set. Exponent obtained the same results as those shown by Dr. Gilbert in the ABC News video but with a 2006 Subaru Impreza Outback. Note that this demonstration was produced under highly artificial conditions where multiple mechanically-created electrical faults, specific resistances, and power supplies were wired into the system through external means to simulate depression of the accelerator pedal. If such circuit faults were actually to occur without deliberate circuit manipulation in an operating vehicle, the presence of such faults would certainly leave "fingerprints" as to their presence.

¹⁶ VIN: JF1GG68686G808933; build date: Nov. 2005

¹⁷ The pedal sensor with higher output voltage was connected through the resistor to the power supply; in our Avalon testing, we also connected the sensor with the higher output voltage to the power supply.



Figure 11. Tested 2006 Subaru Impreza Outback.

5.5 2005 Chrysler Crossfire

Dr. Gilbert's fault creation protocol was applied to the 2005 Chrysler Crossfire shown in Figure 12.¹⁸ As with the Avalon and Camry, this involved mechanically creating two sequential electrical faults. Exponent inserted a set of jumper wires between the pedal assembly and the wiring harness connector to the pedal. The jumper wires enabled electrical interconnections between the wires that carry power and position signals between the accelerator pedal and the ECM. Using these jumper wires, the two pedal sensor output wires were connected through a 200-ohm resistor. The resistance value was identical to that used by Dr. Gilbert when he tested his Avalon. To cause an increase in engine speed, Exponent connected a 5-volt power supply wire to the accelerator pedal through a second resistor of 100 ohms.¹⁹ The demonstration on the

¹⁸ VIN: 1C3AN55L05X053970; build date: Dec. 2004

¹⁹ The pedal sensor with higher output voltage was connected through the resistor to the power supply; in our Avalon testing, we also connected the sensor with the higher output voltage to the power supply.

2005 Chrysler Crossfire resulted in an apparent “sudden” onset of acceleration and engine revving, similar to that shown in Dr. Gilbert’s demonstration. The apparent “sudden” onset of the acceleration was due to artificially creating the second fault in an instantaneous manner.

During the demonstration, the check engine light did not illuminate. After the demonstration, the vehicle’s computer was checked using an OBD-II tool, and no diagnostic trouble codes were set. Exponent obtained the same results as those shown by Dr. Gilbert in the ABC News video but with a 2005 Chrysler Crossfire. Note that this demonstration was produced under highly artificial conditions where multiple mechanically- created electrical faults, specific resistances, and power supplies were wired into the system through external means to simulate depression of the accelerator pedal. If such circuit faults were actually to occur without deliberate circuit manipulation in an operating vehicle, the presence of such faults would certainly leave “fingerprints” as to their presence.



Figure 12. Tested 2005 Chrysler Crossfire.

5.6 Accelerator Pedal Sensor Output Voltages

The accelerator pedal sensor output voltages for the 2008 Honda Accord, 2009 Mercedes E350, 2003 BMW 325i, 2005 Chrysler Crossfire, and 2006 Subaru Impreza Outback were measured for different pedal positions. The results of those measurements are shown in Figure 13 and Figure 14. For the Subaru, the two accelerator pedal position sensors produce parallel and nearly identical output voltages. For the other vehicles, the line slopes for sensor 1 and sensor 2 are different and not parallel to each other. Dr. Gilbert opined in his report that several vehicle manufacturers currently use this fault detection strategy and that a short between the two pedal sensor outputs would be detected by the ECM.²⁰ However, tests with pedal position sensors from five other manufacturers using his strategy demonstrate that the electrical wiring to the pedal can also be manipulated to create an apparent “sudden” onset of acceleration and engine revving.

²⁰ Gilbert Preliminary Report, p 14

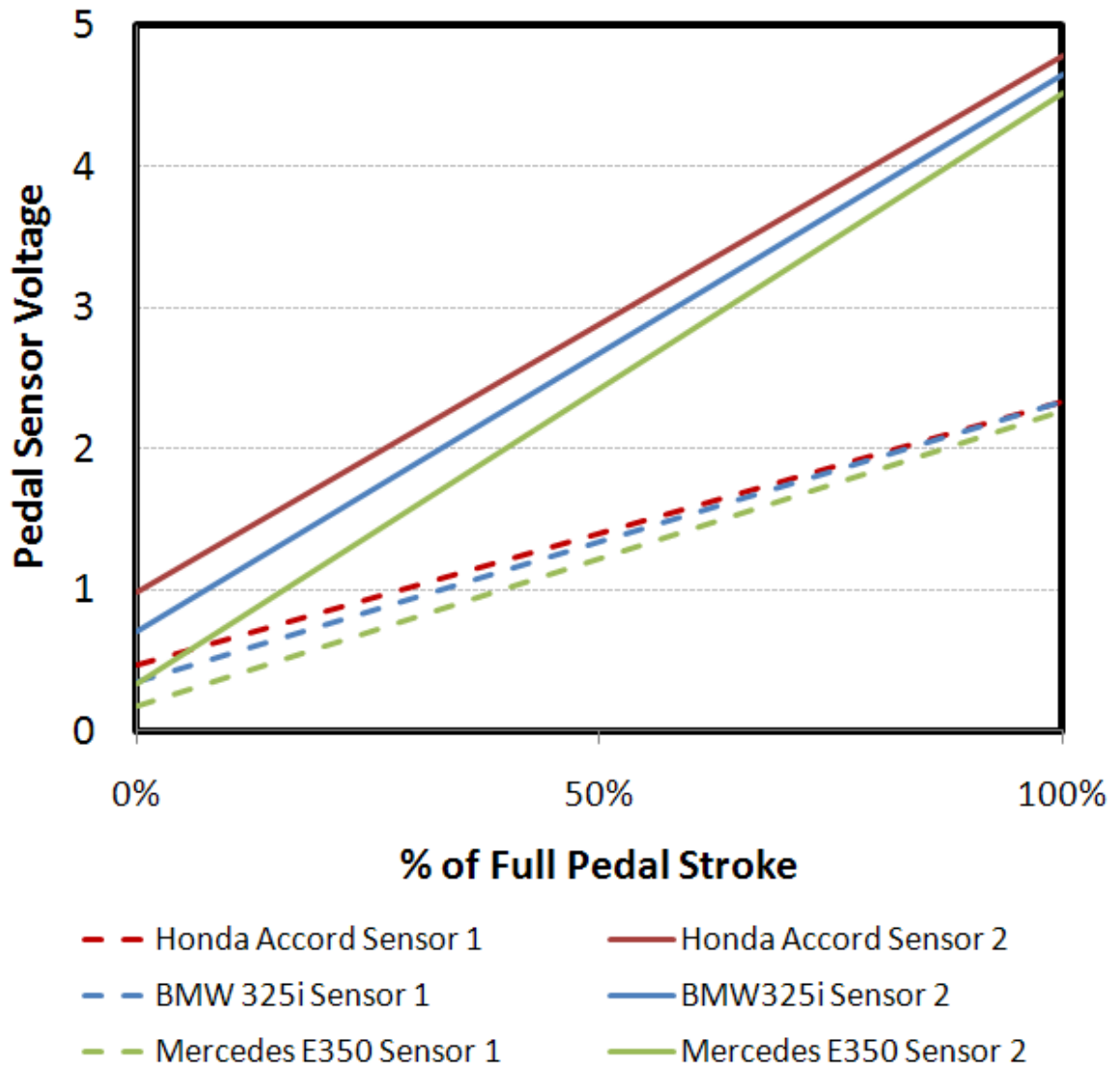

Figure 13. Accelerator pedal sensor output voltages.

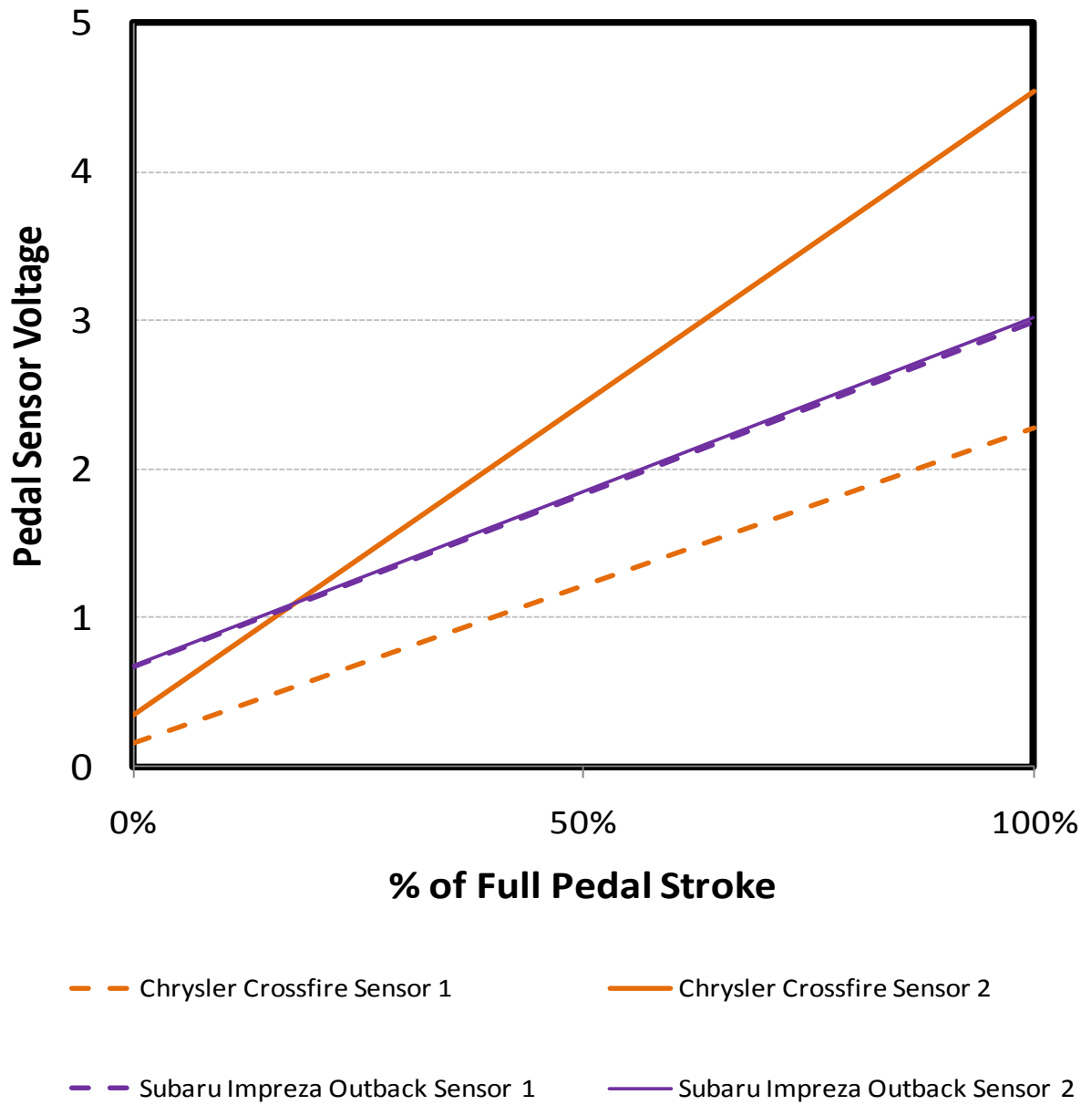

Figure 14. Accelerator pedal sensor output voltages.

March 1, 2010

Appendix A

Wiring Harness to the Accelerator Pedal

Appendix A Wiring Harness to the Accelerator Pedal

Male Pedal Assembly Connector

The pedal assembly male connector (shown in Figure A1) is a molded part attached to the pedal assembly. It has the following characteristics:

- Plastic shell surrounds pins of connector protecting them against direct moisture contact
- Connector pins are located on raised pedestal.
- Connector shell has locking mechanism that interlocks the two-connector portions to prevent connector separation and maintain a seal.

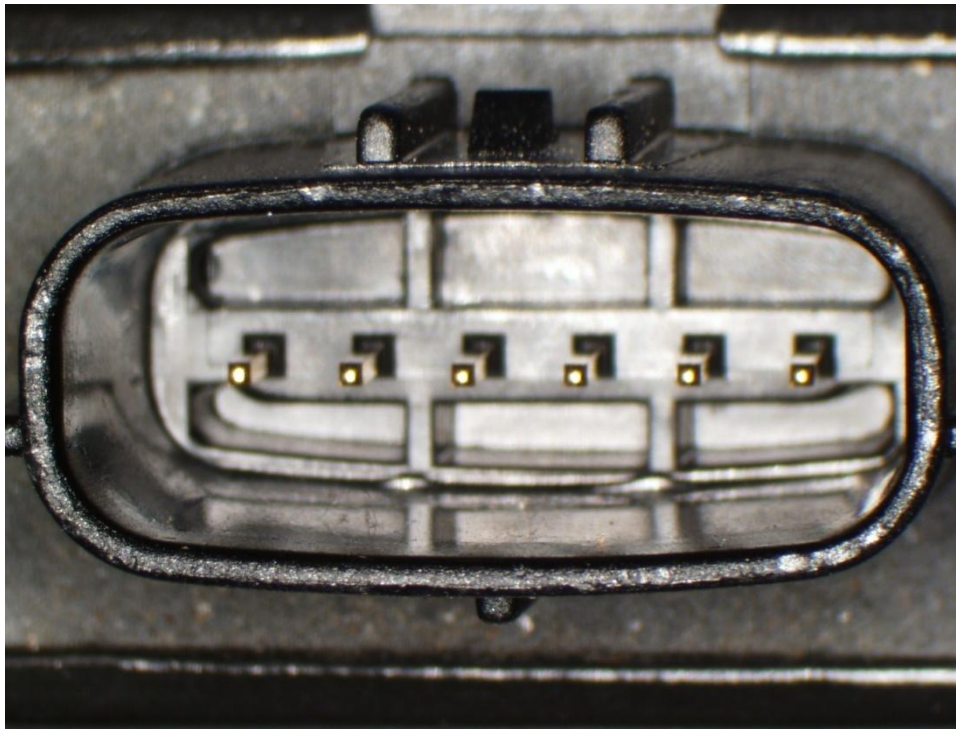

Figure A1. Male portion of connector.

Female Pedal Assembly Connector

The cord-mounted female connector (shown in Figures A2 and A3) has the following characteristics:

- Plastic shell surrounds housing of male portion to prevent direct moisture contact.
- Rubber gasket surrounds rim of female portion making connector waterproof.
- Each pin fits into its own insulated slot to electrically isolate pins from each other.
- Recessed pin sockets reduce the possibility of adjacent pin electrical interconnection on the female side of the connector.
- Plastic divider extends into the connector further reducing the possibility of adjacent pin electrical interconnection.
- Connector wires are individually insulated.
- Wires are individually sealed with separate cylindrical grommets
- Wires are spaced to prevent adjacent wire contact.

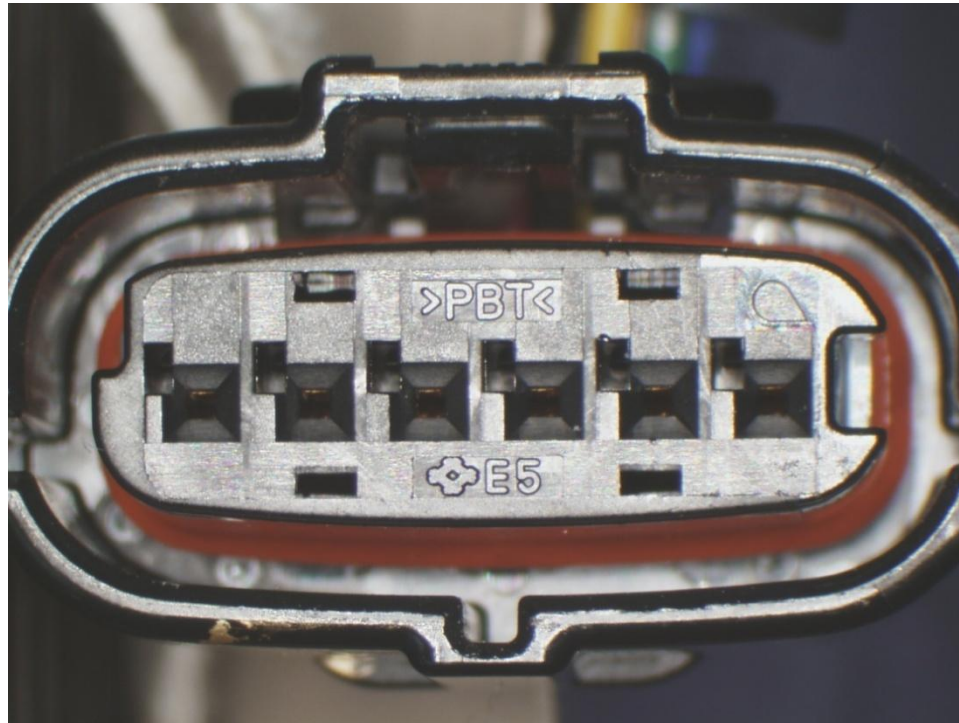

Figure A2. Plastic connector shell surrounds inner connector pedestal to house female sockets. Rubber gasket helps make the connector waterproof. Recessed pins and insulating divider between pins electrically isolates adjacent sockets.

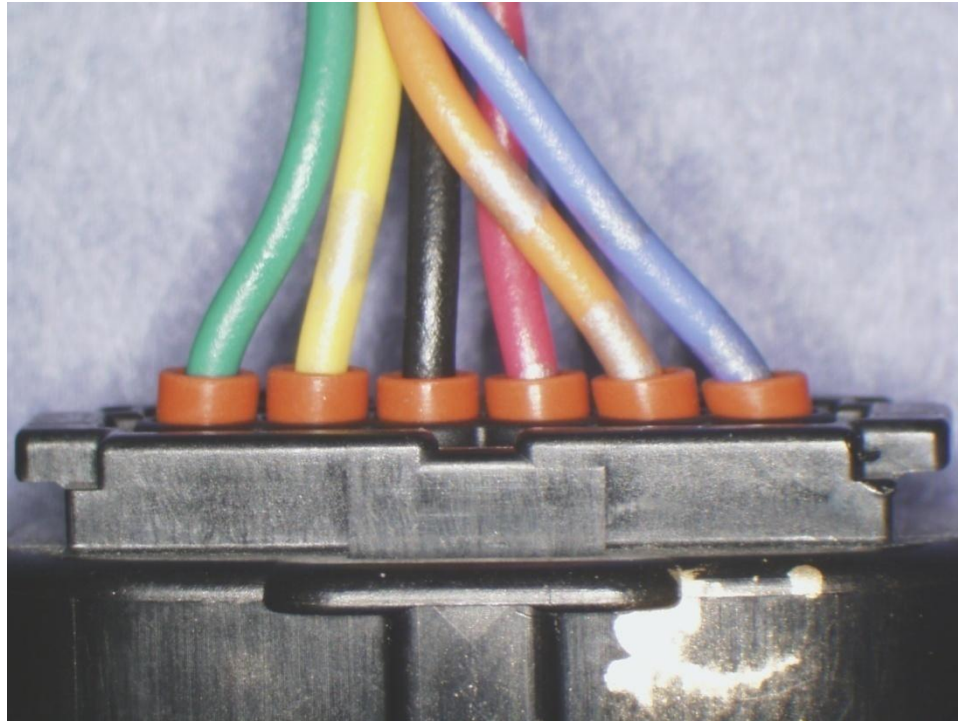

Figure A3. Each connector lead is insulated and protected by a polymeric grommet that helps make the connector waterproof and provides another layer of electrical isolation between sockets.